

# Towards a General Theory of Tax Practice

Social &amp; Legal Studies

2015, Vol. 24(2) 289–312

© The Author(s) 2015

Reprints and permission:

[sagepub.co.uk/journalsPermissions.nav](http://sagepub.co.uk/journalsPermissions.nav)

DOI: 10.1177/0964663915571787

[sls.sagepub.com](http://sls.sagepub.com)**Jane Frecknall-Hughes***Hull University Business School, UK***Erich Kirchler***University of Vienna, Austria*

## Abstract

This article works towards developing a general theory of tax practice by identifying the type of individuals who provide tax services and examining the nature of the fragmented market in which they operate. The empirical studies in the tax practitioner literature have been considered with a view to determining what exactly tax practitioners do and how they interact and deal with the persons on whose behalf they work. This is done with a view to developing a conceptual analysis of their work. Negotiation theory (Wall, 1985) is then posited as a general theory that fits many aspects of tax practitioners and their work, when analysed in this way.

## Keywords

Tax practitioners, conceptual analysis of work, negotiation theory

## Introduction

Back in the early 1990s Erard (1993: 164) claimed, ‘[t]here is at present no general theory of tax practice. Rather there exists a small collection of studies that each focus on particular features of this institution’.

This situation persists today. The work of tax practitioners continues to attract attention and generate significant studies, particularly because of the alleged involvement of tax practitioners in tax avoidance. Doyle et al. (2014) comment that, whilst the Organization for Economic Cooperation and Development (OECD, 2008) study of the role of

---

## Corresponding author:

Jane Frecknall-Hughes, Hull University Business School, Cottingham Road, Hull HU6 7RX, UK.

Email: [J.Frecknall-Hughes@hull.ac.uk](mailto:J.Frecknall-Hughes@hull.ac.uk)

tax practitioners in tax compliance acknowledges that practitioners play a vital role in all tax systems, their role is not straightforward. They are key players, as the article by Bradley in this collection makes clear. They help taxpayers understand and comply with their tax obligations in an increasingly complex world of regulation, but their involvement in giving advice also creates greater complexity in terms of interpretation of the law (see the articles by de Cogan and Picciotto in this collection) and gives cause for concern. This concern relates chiefly to ethics (Shafer and Simmons, 2008) and their involvement in facilitating tax avoidance deemed aggressive or unacceptable by revenue authorities, both in the United States and in the United Kingdom.<sup>1</sup> The 2012 cases of Starbucks, Amazon, Google and Facebook (Barford and Holt, 2012), underline the continuing relevance of examining the work of practitioners, with senior members of large accounting and tax firms being interrogated by the UK government's Public Accounts Committee (Armitstead, 2013; Fuller, 2013). It might appear that tax practitioners are needed to help taxpayers comply with the law and also help them find ways of not complying. How can the apparently different and conflicting roles of tax practitioners be reconciled? This already complex situation becomes even more complicated when one considers that tax practitioners work both in the private sector and in the public sector. If the work of tax practitioners is to be understood, it is necessary to show that their different activities are aspects of an internally consistent theoretical framework.

We first examine who practitioners are, the nature of the market in which they work, and consider the extant literature on taxation practitioners to consider what they do and to determine how they interact with others. This analysis is used to develop a conceptual framework for tax services. Negotiation theory is posited as an underlying construct that goes some way to reconciling the apparently internal conflict in tax practitioners' work, whereby they seem to be involved actively in both compliance and avoidance. It helps provide an understanding of a work role, which is widely misunderstood or misinterpreted, especially by the media.

## Definition of a Tax Practitioner

There is a multiplicity of terms used to describe tax practitioners or tax preparers who are persons, or any such persons' employee, who prepare, for compensation, all or a substantial portion of a tax return or claim for refund (Arzoo, 1987). According to Devos (2012: 5), 'tax practitioner' is a term that:

covers a diverse group of individuals, business structures and professional groups who provide a range of tax services for their clients. Self-employed and in-house accountants, tax advisers and registered tax agents, tax agent franchises and legal practitioners in the tax area are all embraced by the term 'tax practitioner'.

Tax practitioners play a variety of roles in the taxation system, namely, as preparers of tax returns to the tax authorities and responding to queries on the returns from the tax authorities; as advisers on how to arrange a taxpayer's affairs so as to minimize the tax payable; as valuers or mediators if disputes over valuations occur; as tax authorities'

agents in the case of an investigation and within the public sector, as employees of the tax authority.

Strictly, tax practitioners in the private sector will consider that their primary duty is to their clients in such circumstances, though sometimes there is confusion as to whom tax practitioners serve (Hammer, 1996; Jackson and Milliron, 1989). Devos (2012) conducted a study in Australia on the impact of tax practitioners on tax compliance. Generally, the role of tax practitioners has been viewed as representative of both taxpayers and the government; they have to act as advocates for their clients and to serve as intermediaries in the tax system (Brody and Masselli, 1996; Duncan et al., 1989; Yetmar and Eastman, 2000).

With so many facets to their role, the ethical dimensions can be complex. Tax practitioners have a duty towards their clients, the government, their firm, their profession, the wider public, and of course, to themselves. The view of them as government representatives may stem from the fact that technically competent practitioners will consider the stance a taxing authority may take, especially where ambiguous or disputed items are under consideration. There are many ways of looking at the ways in which people and organizations interact, but it is the nature of what the tax practitioner does which will determine the appropriate perspective.

Practitioners will usually act on behalf of one or more parties. If tax practitioners act on behalf of a client, it is common to see them referred to as agents, but this will depend on whether taxpayers remain responsible for their affairs.

Before analysing conceptually the work of tax practitioners, we first examine the nature of the taxation services market in which they work, to establish who is at work there and also the literature on tax practitioners.

## **The Nature of the Taxation Services Market**

The market worldwide for the supply of tax services appears fragmented. There are often large numbers of different types of individuals providing tax services, such as, members of a professional accountancy and/or taxation body whose studies necessarily included taxation to a certain level (seven, for example in the United Kingdom); members of the legal profession and former members of a taxing authority who have moved into private practice. These individuals may work in a variety of entities, for example, a 'one-man band' general accounting practitioner, a small- or medium-sized accounting firm or a Big Four firm (Deloitte, EY, KPMG and PricewaterhouseCoopers) or legal firms. Tax practitioners are also found within the financial function of commercial enterprises, typically multinational groups. A taxing authority too employs a large number of taxation practitioners, who have been trained to various levels internally by that body. The main features therefore of the market for tax services are the lack of any professional monopoly and fragmented professional regulation (Fisher, 1994; Hemans, 1996). Thuronyi and Vanistendael (1996: 160–163) examined the organization of the tax profession in Europe, the United States, Canada and Australia and found a lack of monopoly and fragmentation of regulation. However, this situation is frequently subject to localized variation and change. Registration of paid preparers has been a requirement in Oregon since 1973, in California since 1997 and in Maryland since 2008 (McKerchar et al., 2008),

whilst Federal registration of tax intermediaries in the United States became mandatory from 1 January 2011, along with other mandatory requirements (Frecknall-Hughes and McKerchar, 2013: 276). Generally, elsewhere there is more regulation than in the United Kingdom. The 2009 consultation document, issued by Her Majesty's Revenue and Customs (HMRC), *Modernising Powers, Deterrents and Safeguards. Working with Tax Agents: A Consultation Document*, does suggest, however, some form of registration for the 12,000 estimated tax practitioners who are currently unregulated by any professional body.

The fragmented nature of the market for taxation services, arguably, has adversely impacted on studies of tax practitioners, as it makes a holistic view of the services they provide difficult to obtain. Whilst a considerable amount of academic literature exists on various aspects of taxation work, there exists no major survey of it to detect underlying themes, and consequently, there is little analysis of the work done at a conceptual or theoretical level. This article attempts to address these lacunae.

## Review of the Taxation Practitioner Literature

There is a significant amount of literature looking at different aspects of the work of tax practitioners. Increasing numbers of taxpayers use tax practitioners' services (Klepper and Nagin, 1989a). According to the Treasury Inspector General for Tax Administration (quoted in Leviner and Richison, 2011), the percentage has increased: more than half of taxpayers in the United States pay someone to prepare their income tax return (see also Sakurai and Braithwaite, 2003).

Most empirical studies on tax practitioners have been carried out in the United States. The studies centre around the demand for tax preparation services, the compliance level of returns filed with the assistance of practitioners and the factors that affect practitioners' compliance decisions.<sup>2</sup> Few studies examine the nature of the interaction between client and tax practitioner or suggest reasons for employing a tax practitioner. Those that do so are considered below.

Tomasic and Pentony (1991) found that the role of tax practitioners is sixfold. They are seen as (a) independent advisers of their clients, (b) unpaid employees of the tax administration, (c) intermediaries between the tax administration and their clients, (d) tax advisers, (e) protectors of their practice and (f) as influencers on the tax system (quoted in Devos, 2012).

The demand for tax practitioner assistance arises for the following reasons.<sup>3</sup>

- i. Ensuring that the return is correctly prepared is an important reason for seeking professional assistance. The use of tax practitioners does not seem primarily driven by the desire to avoid paying taxes, but by the uncertainty about tax law and the motivation to report correctly. Niemiowski and Wearing (2003) found a high level of agreement among taxpayers with the following statement: 'Because I do not want to make any mistakes, I use a tax professional to prepare my tax return', and with similar statements. Sakurai and Braithwaite (2003) found that the idealized tax practitioner is a low-risk, no-fuss practitioner who is honest and risk averse. Some respondents found that engagement in cautious

- minimization of tax was acceptable. Although tax practitioners assume that their clients demand aggressive tax planning, only a minority of the respondents indicated a desire for creative, aggressive tax advice. Stephenson (2006) found that tax practitioners tend to be more aggressive than their clients prefer, and Lubbe and Nienaber (2012) found that South African small business firms seek advice from tax professionals mainly because they want their tax returns to be accurate; thus they seek conservative advice.
- ii. Paying the least tax required (or avoiding as much tax as possible) is also a significant reason. However, Leviner and Richison (2011: 9) report that ‘at least 2 million taxpayers overpaid their 1998 taxes by approximately \$945 million because they claimed the standard deduction when it was more beneficial for them to itemize. About half of these taxpayers used a paid tax preparer’.
  - iii. Taxpayers also desire to avoid serious tax penalties.
  - iv. Taxpayers wish to reduce the likelihood of a tax investigation.
  - v. The increasing complexity of the tax system also provides an incentive to employ assistance in completing a return.
  - vi. Klepper et al. (1991) suggest that legal ambiguity over their type of income is a motive for some groups of taxpayers seeking professional assistance. Scotchmer (1989) suggested that resolution of uncertainty is likely to be a primary practitioner function and this could take two forms – completing a correct return that is unlikely to be challenged by the Internal Revenue Service (IRS) and completing one that minimizes taxes whilst taking into account the likelihood of a challenge.

The wish to resolve uncertainty is logically linked with attitudes towards risk. Some studies conclude that when uncertainty is increased, risk-averse taxpayers will report higher levels of income.<sup>4</sup> Christensen and Hite (1997) found significant differences, however, in the factors that affect risk-averse and risk-taking individuals, that is, risk-averse individuals are influenced most by outcomes being described in terms of winning or losing an IRS challenge, whereas risk takers are more sensitive to higher probabilities of success. Tax practitioners, on the other hand, take more aggressive positions when the item under consideration is a tax deductible item rather than additional income.

In the 1980s, two studies (Yankelovich et al., 1984; US Internal Revenue Service, 1988, Appendix B) assessing taxpayer motivation for seeking assistance found that the key reasons were fear of making a mistake (63% of respondents); hope that employing a preparer would save money (13%) and insufficient time to self-prepare the return (11%).

A significant amount of literature on tax, however, has centred on the ‘factors affecting the compliance behavior of US taxpayers’ (Hite and McGill, 1992: 389).<sup>5</sup> A large part of prior research considers tax compliance using a deterrence theory framework (Grasmick and Green, 1980; Tittle, 1980). The general import is that individual taxpayers are deterred from non-compliance in accordance with their perceptions of probable detection and the severity of penalties. A considerable body of research now examines the concept of ‘tax morale’ and why taxpayers do actually comply (Alm and Torgler, 2004, 2006; Torgler, 2007), which includes consideration of the behavioural aspects of tax compliance and evasion based on insights from social and cognitive psychology and behavioural economics (Frey, 1997; Kirchler, 2007). A developing corpus

of research also examines how the extent to which taxpayers trust their government or how the power their government has over them affects compliance (see the 'slippery slope framework' of Kirchler et al., 2008).<sup>6</sup> There is a clear movement away from deterrence towards a developing theme of cooperative compliance between taxpayers and governments (OECD, 2013). The general theory proposed in this article can accommodate such changes.

Until recently, tax compliance research did not consider the likely impact of the tax practitioner on compliance. A significant body of research now finds that practitioner-prepared returns are more non-compliant than those prepared by the individual taxpayer (Erard, 1990, 1993; Klepper and Nagin, 1989a; Smith and Kinsey, 1987). This means that the role of tax practitioners is very important in the compliance process, as practitioners can encourage clients to be compliant or deter them from being so (LaRue and Reckers, 1989). The literature repeats both effects.<sup>7</sup> Klepper and Nagin (1989a) and Klepper et al. (1991) suggest that tax preparers' dual roles arise as a result of the complexity of tax law, that is, they act as 'enforcers' in unambiguous contexts and as 'exploiters' in ambiguous ones which is supported by the findings of Spilker et al. (1999) and Hite et al. (2003). Doyle et al. (2012) investigated the moral reasoning of tax practitioners in social contexts and in tax contexts. Although no differences between tax practitioners and non-tax practitioners were found in ethical reasoning in social contexts, once the context changed to tax, differences in moral reasoning were significant, with tax practitioners utilizing significantly lower level moral reasoning than non-practitioners.

Where a tax practitioner interprets ambiguous situations in the taxpayer's favour, rather than in favour of the taxing authority, this is referred to as being aggressive (Hite and McGill, 1992). Several studies (for example, Ayres et al., 1989; Erard, 1993; Jackson and Milliron, 1989; McGill, 1988; Reinganum and Wilde, 1990; Westat, Inc., 1987) support the idea of levels of 'aggressiveness' from tax practitioners. However, Tan (1999), looking at predominantly small business owners in New Zealand, found that they agreed more with conservative advice given by a tax practitioner and less strongly with aggressive advice. Studies by Collins et al. (1990) and Tan (1999) also found evidence that taxpayers aim for a practitioner who correctly prepares the tax return. Even if taxpayers are presented with an ambiguous tax situation in which their tax adviser provides aggressive or conservative advice, there is no preference for aggressive tax filing in general (Hite and McGill, 1992), although it is agreed that there exist many opportunities for practitioners to engage in unethical activities (Marshall et al., 1998).

Several studies<sup>8</sup> report on the factors affecting tax practitioners' levels of aggressiveness. These have been discovered to be client attributes (quality of records, dependability, etc.), the preparer's own concerns about penalties, possible loss of (an important) client, opinions of others in the firm, advocacy posture, client risk preferences, levels of ambiguity in a particular issue, whether tax is due by the client, tax authority experience, probability of tax investigation, type of firm, certified public accountant (CPA) status or not, education level, whether the decision was taken by one practitioner or a group and ethical concerns. Practitioners can be influenced by one or more different factors and one or more factors may operate in conjunction.

## A Conceptual Analysis of the Work of Tax Practitioners

Thuronyi and Vanistendael (1996: 148–151) identify six different functions performed by tax practitioners. Their analysis is very general and includes situations that pertain worldwide:

1. *Tax planning*. This is viewed as a: This analysis is important as it recognizes inherently the interdisciplinary nature of tax services, which is a factor complicating attempts at analysis and regulation.
2. *Advice ancillary to financial and other services*. Entities such as banks, insurance companies and real estate companies will often provide tax advice in relation to the products that they sell. The advice will typically be narrow in scope and tailored to particular products. This is not the same as the type of services provided by more 'general' practitioners.
3. *Preparation and auditing of commercial accounts*. This is not usually done by the same professionals who would calculate any tax liability arising from commercial accounts, at least in the United Kingdom. The point which Thuronyi and Vanistendael (1996) make, however, is that the preparation and auditing of accounts, whilst regulated stringently by other bodies, is not regulated by tax authorities. Hence tax practitioners will be obliged to accept figures provided by others to work on, so the work of other professionals has an impact.
4. *Preparation of tax returns*. This is where taxpayers hire a practitioner to complete and submit their tax return to the tax authorities.
5. *Representation of the taxpayer before the tax administration*. Here tax practitioners act as advocates on behalf of taxpayers, though, depending on the type of representation required, this may additionally or alternatively be shared with other professionals, such as lawyers.
6. *Representation before the courts*. This is not unlike category (v) but may represent a stage beyond (v), where representation before the tax authority has failed, particularly if the matter is one that may be construed as a civil matter. If the issue involves tax fraud or evasion, then the issue is likely to go straight before the courts. Under the UK's legal system, representation at this level is likely to involve primarily members of the legal profession.

much wider package of legal and economic services, including auditing, accounting, financial, legal and management services. Tax problems can arise not only from the company's accounts and records, but also from legal obligations flowing from company law, securities regulation, bankruptcy law, and so on. Therefore it is important to recognise that many different kinds of professionals will deal with tax problems as a natural extension of their non-tax activities. (Thuronyi and Vanistendael, 1996: 149)

Thuronyi and Vanistendael (1996) consider these different functions foremost to see whether they each require a different kind of regulation. If so, this would create a



complex situation, as within an accounting firm, for example, one tax practitioner may provide several different services.

There is, however, another way of looking at the service provided by tax practitioners. The analysis below is provided with a view to developing a general theory of tax practice. Generally the work of tax practitioners may be categorized into two basic kinds, namely, tax compliance work and tax planning/avoidance/mitigation advice (Frecknall-Hughes and Moizer, 1999). Tax compliance work involves the preparation of tax computations for submission on the taxpayer's behalf to the tax authorities, dealing with subsequent queries and the resolution of any uncertainties. Tax planning (or avoidance or mitigation) work occurs when the tax practitioner attempts to devise ways of reducing the taxpayer's liability to tax or maximizing after-tax returns (see the article by Gribnau in this collection). It should be said that this categorization is not universally agreed, as many would analyse the work done into further divisions and/or subdivisions or see certain work as comprising elements of the two basic categories of compliance or planning, though most would accept tax planning as a separate category (Stainer et al., 1997).

### *Tax Compliance Work*

This involves reporting the economic events that have occurred. The aim of tax practitioners will be to ensure that the reporting of these economic events complies with tax law, but using whatever latitude is possible to present the information in the best possible way to serve a client's interests. Tax legislation may contain 'grey' areas, where the law is unclear, although often it is the situation to which the legislation is applied that is ambiguous. For example, the law may be clear on the tax treatment of repairs to buildings as distinct from capital expenditure, but it may be difficult in reality to distinguish a repair from capital enhancement. Hence, if a building requires a new roof because a storm has destroyed the old roof, the new roof would inevitably contain some improvement (given advances in construction materials and techniques over time), especially if the building owner deliberately took the opportunity to install a better roof. This would make the dividing line between capital and repairs even harder to define. In such cases, tax practitioners may have some scope for creative tax reporting. In addition, there will inevitably be areas of tax reporting where the amounts to be entered in the tax returns are subject to uncertainty and hence to an overt process of negotiation with the tax authorities. Such negotiations can be considered to be a legitimate part of the tax process, because it is normal for some uncertainty to arise in particular circumstances. Typically, this will cover areas where values have to be agreed and may be the subject of differing professional opinions, such as determining the value of unquoted company shares with no stock market price, or the value of real estate.

### *Tax Planning Work*

This category involves a definite and deliberate manipulation of the taxpayer's affairs to reduce the amount of tax payable. For example, in the United Kingdom, inheritance tax may be charged on an individual's death where the value of assets in the estate, or given



prior to death, exceeds certain exempt bands. In order to provide some relief, gifts taking place more than 7 years before death are exempt and so it is possible to avoid paying some or all of the potential inheritance tax by making lifetime transfers of assets directly to the intended beneficiaries or indirectly into trusts. Hence, it is a normal part of inheritance tax planning to devolve estates so as to preclude legitimately a tax burden occurring on death. Such tax planning involves deliberately framing reality in a particular way to ensure that taxpayers are enabled to act pre-emptively in order to obtain future benefits, which they would otherwise miss because of a lack of knowledge of the technicalities of tax law. It is also possible for tax practitioners to go further and deliberately test a tax statute, which is unclear or ambiguously written, or where issues arise that are not the subject of specific statute or case law precedent. Such testing is at the outer extremes of tax planning and may involve the establishment of complex or artificial schemes with the aim to avoid tax. In the past, these schemes have come not infrequently to the courts for a decision as to their legitimacy. Such avoidance schemes typically use the law in complex ways and are characterized by exploitation of loopholes, a high degree of artificiality and legal and/or financial 'engineering', and whilst they comply with the letter of the law, they breach its spirit.

A distinction is generally drawn between *avoidance* of tax, which is regarded as legitimate, and *evasion*, which is not. The term tax evasion is usually used to mean illegal avoidance of tax, and may be achieved by a variety of means, from falsely reporting transactions which have, or have not, occurred, to setting up artificial transactions. However, the extent to which transactions may be regarded as legitimate avoidance or illegitimate evasion (and so where the dividing line may be drawn) depends on the legal, social or political climate of the time. 'Tax avoidance' is a term coined (by Seldon, 1979) to describe activity, behaviour or transactions where it is unclear as to which side of a dividing line between legality and illegality they fall, especially if one considers that taxpayers should comply not only with the letter of the law but also with its spirit.

However, in the early years of the 20th century, avoiding tax was acceptable, with Lord Clyde, for example, famously saying that no one was morally or otherwise obliged to enable the revenue to 'put the largest possible shovel into his stores'.<sup>9</sup> Legal attitudes gradually changed, as witnessed by Lord Denning's remark in *Re Weston's Settlements* that '[t]he avoidance of tax may be lawful, but it is not yet a virtue'.<sup>10</sup> To combat avoidance, the UK tax authority has developed a number of weapons, namely, legal enactments of various kinds, such as Targeted Anti-Avoidance Rules, which, along with additional reliefs/exemptions, and so on, added in each year's Finance Act or Acts (Foreman, 1996: 2) have increased the volume and complexity of tax law; resorting to the courts to establish the legal acceptability of schemes, as in the *Ramsey* case,<sup>11</sup> which reversed the usual 'form over substance' approach long supported by the UK courts and informed decisions in much subsequent tax case law; and the introduction of disclosure of tax avoidance schemes (DOTAS) in 2004, requiring promoters of avoidance schemes (often tax advisers) to provide details of schemes to HMRC.

DOTAS is regarded as having been effective in eliminating at an early stage many schemes that would otherwise have resulted in court cases. However, it has been unable to address the use by multinationals of what might be termed 'tax arbitrage', that is, the trade-off of one country's tax laws against another's to structure business operations

internationally to gain tax advantage – hence the cases of Starbucks, and so on, referred to earlier. However, there have now been calls by governments to tackle this sort of international tax avoidance, and the OECD's project of Base Erosion and Profit Shifting is one recent response.

Another weapon has been the use of the 'moral card' presaged by Lord Denning's remarks in *Re Weston's Settlements*, combined with a noticeable, subsequent change in language. Whilst tax avoidance remains legal, the use of the word in many official contexts is to suggest that it is the same as evasion, which it is not.

Customs & Excise appears now to use the term 'legitimate avoidance' to distinguish between what they clearly believe to be 'illegitimate' avoidance and 'the legitimate desire to organise affairs in a tax efficient way'. These deliberate attempts to confer an aura of illegality to a legitimate activity is dangerous, and should not be allowed to continue unchallenged. (Peter Wyman, Head of Tax at Coopers & Lybrand, 1997: 3)

This approach blurs terminology and shifts this kind of behaviour (which might hitherto have been acceptable) on to a morally dubious ground. In times of economic hardship, when reduced tax take adversely affects the provision of public services, this device appears to have been effective in focusing attention on the activities of multinational companies. The UK Chancellor of the Exchequer in his 2012 Budget speech specifically referred to aggressive tax avoidance as being 'morally repugnant' (Krouse and Baker, 2012).

A further anti-avoidance device has been the introduction of a general anti-abuse rule (GAAR), which came into force on 13 July 2013, and is designed to provide a legal lens through which to view and judge activity without the need to put in place additional anti-avoidance measures. It remains to be seen how effective it will be.<sup>12</sup>

The idea of tax planning encompasses all of the above activities and tax practitioners will be involved in the full range.

## Possible Theories of Tax Practice

Tax practitioners deal both with their clients and the taxing authority and are placed somewhere between the two. As shown in this section, 'A conceptual analysis of the work of tax practitioners', practitioners undertake different types of work, some of which may actually be unsuccessful (failed planning schemes, and so on). The task remains of developing a general theory to fit these different types of work and encompass all the individuals who may perform it. There are six possible theories that have some claim to be considered, namely, game theory, agency theory, exchange theory, prospect theory, stakeholder theory and finally, negotiation theory. To demonstrate the validity or otherwise of all these theories is beyond the scope of one article, and indeed, would merit several separate studies. We concentrate here on demonstrating the relevance of negotiation theory. In particular, we feel that it copes well with the complex interaction between humans, which is involved in tax practice, and, in particular, encompasses effectively the concept of tax planning work, even in instances where the planning can be rejected, or never come before a client (because unworkable), or might fail. This is not to claim that

the negotiation theory is the perfect underlying theory. As we acknowledge in our conclusion, there are some difficulties.

One of the best expositions of negotiation theory was developed by Wall (1985) in his book *Negotiation Theory and Practice*. In this he develops the theory by reference to finalized, past negotiations. We follow closely Wall's theory but develop it to show its relevance to taxation work.

### *Negotiation Defined*

'Negotiation deals with two participants who have different needs and viewpoints attempting to reach an agreement on matters of mutual interest' (Martin et al., 1999: 65) and:

... seeks to find an agreement that will satisfy the requirements of two or more parties in the presence of limited common knowledge and conflicting preferences. Negotiation participants are agents who negotiate on their own behalf or represent the interests of their principals'. (Braun et al., 2006: 271)

Many writers consider negotiation in the context only of conflict resolution (Wall, 1985: 132), but it applies far beyond these confines. It is predominant in politics, diplomacy, religion, the law and the family (Young, 1991: 1) even though the activity may not be called negotiation ('Who will pick up the kids?') or recognized as such. The word negotiate derives from the Latin *negotior* (Oxford English Dictionary, 1993), which means 'to do business', especially in the sense of 'trading', 'trafficking' and 'banking'. Although rooted in business, the word often has political connotations, as negotiation has long been integral to diplomatic training (de Callières, 1716). However, it was rare until the last 50 years to find negotiation considered holistically as a self-contained subject. The literature is now extensive, but much of it constitutes practical manuals on 'how to negotiate', often from a particular perspective, and involving some aspects of alternative dispute resolution. There has been relatively little on the theory (Kressel and Wall, 2012). However, such theory as there is has been developed contemporaneously with the practical models. Wall's 1985 text comes later than the practically orientated, seminal work of Fisher and Ury (1981) but is more appropriate here because of its theoretical perspective.

Wall (1985: 4) defines negotiation as:

a process through which two or more parties coordinate an exchange of goods or services and attempt to agree upon the rate of exchange for them. In this interaction, the primary objective may be an agreement or any other outcome indigenous to or resulting from the ongoing exchange.

Figure 1 is a simplified paradigm of negotiation. In any negotiation there will be involved a negotiator (negotiator 1 in Figure 1), typically representing one or more parties (negotiator 1's constituent) as well as an opponent (negotiator 2) similarly acting on

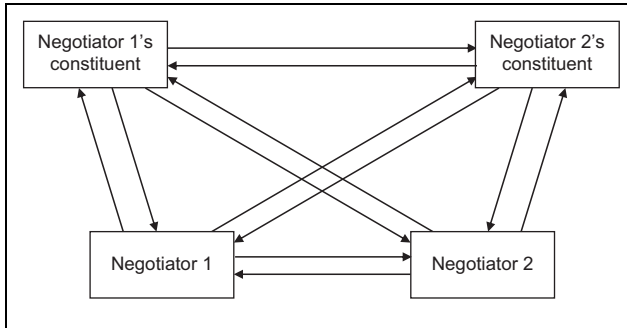

**Figure 1.** Negotiation paradigm developed from Wall (1985: 23).

behalf of one or more parties (negotiator 2's constituent). Each negotiator will see the other as an opponent.

In terms of a tax scenario, the negotiators are the tax practitioner (negotiator 1) and the individual tax authority figure (negotiator 2), acting respectively on behalf of a client (constituent 1) and the taxing authority (as an arm of government, constituent 2). In Figure 1, there are six potential relationships, as indicated by the six sets of double arrows, which also indicate possible information flows or exchanges. Each party derives benefits or incurs costs as a result of interaction with other parties. The difference between benefits and costs yields a net outcome to any given party for each interaction (i.e. a trade-off). In any interaction, the benefits and costs arise from two sources, namely, the interactions between parties as part of the ongoing exchange and the agreement that results from this exchange (the process itself and the outcome of the process). This may vary according to the aims of the individuals involved. Wall models the net outcome of a negotiation using algebra, and this is included in Appendix 1 for completeness.

Negotiation theory to explain the interaction between the taxpayer, tax practitioner, tax authority figure (tax inspector, henceforth, for ease of reference) and tax authority works at many different levels. For example, in the instance of taxpayers submitting their tax returns to a tax inspector, this may be regarded as an opening move in a negotiation, which will expect a response from the inspector. The tax return may be agreed without difficulty, but it may not be if the inspector raises queries, at which point taxpayers might seek the advice of a tax practitioner, if they do not already employ one. (In the case of a large corporate taxpayer, it is likely that a tax adviser (or firm) will have been involved in completion of the return.) There may be a considerable amount of correspondence and/or meetings between a taxpayer, tax practitioner and tax inspector before queries are resolved, with the potential for disagreement to escalate such that tax tribunals or the courts might ultimately be involved.

Open communication of moves in this way constitutes *explicit* negotiation, whereby typically, parties make demands, state preferred courses of action, ask for information, offer proposals, make concessions, and so on (Strauss, 1978). The parties will not, in such circumstances, necessarily know each other's preferred outcomes, although this

would be usual in a tax situation. *Tacit* negotiation occurs when communication is not carried out openly. It is indirect and involves the use of hints, signs, signals, gestures and 'reading between the lines'. Tacit negotiation may be used where it is impossible to communicate openly or completely, where there is distrust or where explicit negotiation is not the usual form of dealing with a given issue. Sometimes tacit negotiation may complement and/or accompany an explicit negotiation and can prevent loss of face for the negotiating parties (Pruitt, 1971).

### *The Stages of Negotiation*

A difference between a tax negotiation and many others is that tax is governed by a complex set of rules that provide a framework within which negotiators must operate, and which they must use to develop their negotiation approach. However, because the rules, or the situation to which they are applied, are open to interpretation (as demonstrated in the sections on Tax Compliance Work and Tax Planning Work), this may affect the outcome and determine where the decision-making power lies to bring the negotiation to a conclusion. This power will sometimes lie unequivocally with the tax inspector, but not always, as it may depend on the nature of the negotiation. Prima facie, however, there is an unequal balance of power in favour of the tax inspector and tax authority, although this would be tempered if the courts became involved.

According to Douglas (1957, 1962), followed by Wall, there are typically three stages to the negotiation process, namely, (i) establishing the negotiation range, (ii) reconnoitring the negotiation range and (iii) precipitating the crisis or agreement. These are less abstract when applied to a particular situation, and here we use the instance of establishing a value for unquoted company shares. We assume the following scenario. A dies, having bequeathed in his will shares in a family company to his son. We further assume that inheritance tax is payable on death.

For the purposes of the estate on death, the legatee would want a low value for the shares, as this would result in a lower inheritance tax bill. However, should the legatee in due time wish to dispose of his shares (e.g. by gift), then a higher base cost on acquisition would result (*ceteris paribus*) in a lower capital gains tax charge. From the perspective of a tax inspector, more tax would be payable if there were a high value on death and a low one for subsequent disposal purposes. This is a very obvious instance where a value would have to be negotiated. The taxpayer/tax practitioner would typically start the negotiation, by calculating a range of values for the shares, using various financial models, with the tax inspector doing the same, though given their respective starting points, it is unlikely that they would agree immediately. However, values calculated by the taxpayer/tax practitioner and tax inspector would provide a range within which any final agreed value would lie, so they would thus have established the negotiation range – stage (i) above.

During stage (ii), reconnoitring the negotiation range, there would be typically 'circling' manoeuvres, whereby the taxpayer/tax practitioner and tax inspector would correspond and/or meet and probe the boundaries of the range of values, to see if there were possibilities of concession by the opposing party and to attempt to reduce the negotiating range. At the final stage (iii), precipitating the crisis or

Nature:	One-shot Repeated Sequential Serial Multiple Linked
Issues:	Number Importance Complexity Prominence Tangibility Sequencing Interdependence
Range of possible outcomes:	Interdependence Number of feasible agreement points Pay-offs at each alternative Constraints

**Figure 2.** Negotiation components adapted from Wall (1985: 105).

agreement, the parties would attempt to reach agreement, whilst still probing to exploit any weaknesses in the opponent's position – but, perhaps, with an eye to the future, as they would be mindful that this might not be the only occasion on which they might have to deal with one another, which brings us to consideration of the nature of the negotiation and its components, as shown in Figure 2.

It is sometimes difficult to decide on the nature of a negotiation. In terms of a tax practitioner representing a client, all items on the above list could apply, depending on the circumstances. In the case of a tax practitioner representing a client in negotiating a value for unquoted shares, for example, the actual subject matter of the negotiation might determine that it is a one-shot. It could be repeated in that the tax practitioner might have represented another client on a similar subject and dealt with the same tax authority officials. It might be sequential if it followed another negotiation, even though that might not involve the same subject: in this instance the tax practitioner would be acting for the same client. Likewise it could be one of a related series of negotiations, depending precisely on the nature of the client's affairs. As a tax practitioner will have many clients to deal with, the negotiation might be one of a multiple. It all depends on whether there is an existing relationship between client and practitioner and the type of tax issue involved.

A negotiation can cover one issue or many issues, which can vary in importance and complexity. Agreement might be required as to a value for unquoted shares (one issue, important, complex), or on the allowability (or otherwise) of items of expenditure in financial statements (several issues, varying complexity, but often almost routine). Important issues are often complex ones, especially if they are interdependent or where there may be a number of different possible points of agreement.



**Figure 3.** Development of a negotiation strategy taken from Wall (1985: 127).

### *Negotiation Strategy and Tactics*

Wall (1985: 68 and 127) sees negotiation strategy (a broad plan) essentially as a weaving together of tactics (strategy components) into a ‘synergistic plan’ and develops a negotiation strategy along the lines shown in Figure 3.

Tactics are further described by Wall (1985: 48) as ‘the most salient aspects of negotiation (which) form multiple labyrinths for the investigator probing into the negotiation process’. He is one of the few writers to develop an analysis of tactics in the context of negotiation, which he sees as largely sidelined in the literature and sees tactics as divisible into two categories, namely, rational tactics and irrational tactics.

Rational tactics include the use of persuasion, threats, rewards, cheating and frightening towards an opponent, in a manner which the opponent will understand and reciprocate. Hence they appear rational to both parties. Irrational tactics occur when one party does not understand why a particular action has taken place. For example, one negotiator might suddenly break off a negotiation even though he/she appears to be on the way to obtaining the desired outcome. The irrationality may be adopted deliberately as a tactic to ‘put off’ the opponent, hence may in this sense be rational to the adopter, or it may result from, say, frustration with the process, and be an expression of emotion, and therefore be genuinely irrational. However, most negotiation tactics will be encompassed within the rational category.

An important feature of Wall’s (1985) model is this incorporation of strategy and tactics, because when applied to tax practice, it can include not only the idea of tax planning, but can also deal with instances where planning does not work. Any tax ‘scheme’ developed by a tax practitioner designed to avoid tax would be the outcome



of deliberate planning, involving strategy and tactics within manoeuvres aimed at securing agreement from HMRC. It might succeed, which would mean that a tax practitioner had succeeded in using the tax rules to a client's benefit. It might, equally, not succeed, in which case a different strategy or tactics may be developed, or an entirely new negotiation opened, or, indeed, 'damage limitation' undertaken to negotiate the best outcome where a scheme has failed. The process here is arguably the same, whether the practitioner helps a taxpayer through the minefield of tax rules to ensure compliance or to achieve avoidance, and thus negotiation theory is useful in reconciling situations where a tax practitioner's work seems to have conflicting outcomes.

## Conclusion

We have in this article gone some way towards developing a general theory of tax practice, taking account of all the different types of work that tax practitioners undertake and which has been identified as missing. We have examined the type of individuals at work in tax practice and have shown how the nature of the fragmented market in which they operate contributes to the lack of a holistic view being taken of tax practitioners' work. The empirical studies in the tax practitioner literature have been reviewed to determine what exactly tax practitioners do, how they interact with the persons for and with whom they work, hence to help develop a conceptual analysis of their work (tax compliance and tax planning). Negotiation theory is then posited as a general theory fitting tax practitioners and their work, when analysed in this way. We have argued that this fits all the different types of work undertaken by practitioners and inherently includes consideration of both private and public sector practitioners, thus providing a consistent and coherent underlying theoretical framework. Significantly, the framework is capable of accommodating changes in the model of behaviour between tax authorities and their citizens, which is inherent in the newer concepts of cooperative compliance. We do not, however, claim that negotiation theory will necessarily fit perfectly all aspects of taxation work. For example, the negotiating power of a revenue authority figure in many cases may exceed that of a taxpayer or tax practitioner, and there may be a materiality threshold which might apply so that issues did not come to a negotiation. In addition, other theories (e.g. game theory and stakeholder theory), as mentioned earlier, may also offer an alternative possibility for an underlying theoretical construct.

## Appendix I

The net outcome accruing to each party in a negotiation (an algebraic representation of the negotiation paradigm per Wall (1985: 23)).

This can be expressed symbolically as:

$$NO = NO_{(\text{interactions})} + NO_{(\text{agreement})}$$

If the outcomes could be identified at the end of the negotiation, then the net outcome to Party (i) would be given by:

$$NO_i = \sum_j (R_{nij} - C_{nij}) + (R_{ai} - C_{ai})$$

where:

$NO_i$  = Net outcomes accruing to Party (i).

$R_{nij}$  = Reward to Party (i) resulting from interaction with Party (j).

$R_{ai}$  = Reward to Party (i) resulting from the agreement.

$C_{nij}$  = Cost to Party (i) resulting from interaction with Party (j).

$C_{ai}$  = Cost to Party (i) resulting from the agreement.

$\sum_j$  denotes the sum of all the interactions with Party (j).

However, during the negotiation, the negotiators may have to forecast the outcomes and will have expectations of the outcomes based on their own probabilistic estimates. The above ex-post model can then be written in an ex-ante form as follows:

$$E(NO_i) = \sum_j [E(R_{nij}) - E(C_{nij})] + [E(R_{ai}) - E(C_{ai})]$$

where the terms have the same meaning as above, other than that the preceding  $E$  denotes an expected value.

## Notes

1. See for example, most recently, Hasseldine and Morris, 2013; Sikka, 2010; and Wilson, 2009.
2. See Blumenthal and Slemrod, 1992; Dubin et al., 1992; Kinsey, 1987; Klepper and Nagin, 1989b; Reinganum and Wilde, 1988; Sawyers, 1990; Slemrod, 1989; and Swingen et al., 1991.
3. The specific articles cited in this section comprise only a small sample of an extensive body of literature. Additionally relevant are studies by Anderson, 1997; Ashley and Segal, 1997; Beck and Jung, 1989; Christensen, 1992; Christensen and Hite, 1997; Collins et al., 1990; Devos, 2012; Fisher, 1994; Frischmann and Frees, 1999; Gurley, 1996; Hite and McGill, 1992; Hite et al., 1992; Kinsey, 1987; Klepper and Nagin, 1989a; Scotchmer and Slemrod, 1989; Smith and Kinsey, 1987; Tan, 1999; White, 1990.
4. See Alm, 1988; Beck et al., 1991; Chang et al., 1987; Hite and Stock, 1995; and Scotchmer, 1989.
5. See also Fischer et al., 1992; Jackson and Milliron, 1989; Roth et al., 1989; and Weigel et al., 1987.
6. See also Kirchler et al., 2010; Kogler et al., 2013; Muehlbacher and Kirchler, 2010; Muehlbacher et al., 2011; and Wahl et al., 2010.
7. See Ayres et al., 1989; Duncan et al., 1989; Erard, 1990; Kaplan et al., 1988; Pei et al., 1992.
8. See Bandy et al., 1994; Burns and Kiecker, 1995; Carnes et al., 1996a, 1996b; Cloyd, 1991; Cruz et al., 2000; Duncan et al., 1989; Helleloid, 1989; Johnson, 1993; Kaplan et al., 1988; LaRue and Reckers, 1989; McGill, 1988; Milliron and Toy, 1988; Newberry et al., 1993; Reckers et al., 1991; Roark, 1986; Schisler, 1994; and Schmidt, 2001.
9. *Ayrshire Pullman Motor Services and Ritchie v. CIR* [1929] 14 TC 754 at 764–765. The sentiment was echoed in *IRC v. Duke of Westminster* [1936] AC 1 at 19–20. Legal opinions were much the same in the United States at the time. See, for example, the comments of Learned Hand, in the case of *Gregory v. Helvering*, 1935 (US Supreme Court).
10. [1969] 1 Ch 223 at 245.
11. *Ramsay (W.T.) Ltd v. CIR* [1982] AC 300.

12. The United Kingdom mooted the introduction of a General Anti-Avoidance Rule (also referred to by the acronym GAAR) in 1997, which was different in concept and was not introduced for various reasons.

## References

- Alm J (1988) Uncertain tax policies, individual behavior and welfare. *American Economic Review* 78(1): 237–245.
- Alm J and Torgler B (2004) Estimating the determinants of tax morale. In: *National Tax Association – Tax Institute of America. Proceedings of the Annual Meeting*, pp. 269–274. Washington DC: National Tax Association.
- Alm J and Torgler B (2006) Culture differences and tax morale in the United States and in Europe. *Journal of Economic Psychology* 27(2): 224–246.
- Anderson KE (1997) *Tax avoidance by individuals: Paid-preparer versus self-prepared returns*. PhD dissertation by Gurley III, AL, University of Mississippi, 1996, reviewed in *Journal of the American Taxation Association* 19(1): 118–119.
- Armitstead L (2013) Big Four Accountants blast tax scheme claims. *The Telegraph*, 26 April. Available at: <http://www.telegraph.co.uk/finance/personalfinance/consumertips/tax/10018397/Big-Four-accountants-blast-tax-scheme-claim> (accessed 18 August 2013).
- Arzoo GA (1987, January), Preparer penalties and compliance. *Tax Adviser*, 36–43.
- Ashley T and Segal MA (1997) Paid tax preparer determinants extended and reexamined. *Public Finance Review* 25(3): 267–284.
- Ayres FL, Jackson BR and Hite PS (1989) The economic benefits of regulation: Evidence from professional tax preparers. *Accounting Review* 64(2): 468–487.
- Bandy D, Betancourt L and Kelliher C (1994) An empirical study of the objectivity of CPAs' tax work. *Advances in Taxation* 6: 1–23.
- Barford V and Holt G (2012) Google, Amazon, Starbucks: The rise of 'tax shaming'. Available at: <http://www.bbc.co.uk/news/magazine-20560359> (accessed 29 December 2012).
- Beck PJ and Jung WO (1989) Taxpayers' reporting decisions and auditing under information asymmetry. *Accounting Review* 64(3): 468–487.
- Beck PJ, Davis JS and Jung WO (1991) Experimental evidence on taxpayer reporting under uncertainty. *Accounting Review* 66(3): 535–558.
- Blumenthal M and Slemrod J (1992) The compliance cost of the US individual income tax system: A second look after tax reform. *National Tax Journal* 45(2): 185–202.
- Braun P, Brzostowski J, Kersten G, et al. (2006) E-Negotiation systems and software agents: Methods, models and applications. In: Gupta JND, Forgione GA and Mora M (eds) *Intelligent Decision-Making Support Systems*. London: Springer, pp. 271–300.
- Brody RG and Masselli JJ (1996) Tax preparers: Whose team are they on? *National Public Accountant* 41(3): 18–46.
- Burns JO and Kiecker P (1995) Tax practitioner ethics: An empirical investigation of organizational consequences. *Journal of the American Taxation Association* 17(2): 20–49.
- Carnes GA, Harwood GB and Sawyers RB (1996a) The determinants of tax professionals' aggressiveness in ambiguous situations. *Advances in Taxation* 8: 1–28.
- Carnes GA, Harwood GB and Sawyers RB (1996b) A comparison of tax professionals' individual and group decisions when resolving ambiguous tax questions. *Journal of the American Taxation Association* 18(2): 1–18.

- Chang OH, Nichols DR and Schultz JJ (1987) Taxpayer attitudes towards tax audit risk. *Journal of Economic Psychology* 8(3): 299–309.
- Christensen AL (1992) Evaluation of tax services: A client and preparer perspective. *Journal of the American Taxation Association* 14(2): 60–80.
- Christensen AL and Hite PA (1997) A study of the effect of taxpayer risk perceptions on ambiguous compliance decisions. *Journal of the American Taxation Association* 19(1): 1–18.
- Cloyd CB (1991) The effects of accounting method, ambiguity type and client risk preferences on recommendations of tax preparers. Paper presented at *Midyear Meeting of the American Taxation Association*, Albuquerque, New Mexico, February.
- Collins JH, Milliron VC and Toy DR (1990) Factors associated with the household demand for tax preparers. *Journal of the American Taxation Association* 12(1): 9–25.
- Cruz CA, Shafer WE and Strawser JR (2000) A multidimensional analysis of tax practitioners' ethical judgments. *Journal of Business Ethics* 24(3): 223–244.
- de Callières F (1716) *On the Manner of Negotiating with Princes*, translated by Whyte AF (1919). Boston, MA: Houghton Mifflin.
- Devos KNH (2012) The impact of tax professionals upon the compliance behavior of Australian individual taxpayers. *Revenue Law Journal* 22(1): 1–26. Available at: <http://epublications.bond.edu.au/cgi/viewcontent.cgi?article=1223&context=rjlj> (accessed 10 April 2013).
- Douglas A (1957) The peaceful settlement of industrial and inter-group disputes. *Journal of Conflict Resolution* 1: 69–81.
- Douglas A (1962) *Industrial Peacemaking*. New York, NY: Columbia University Press.
- Doyle E, Frecknall-Hughes J and Summers B (2012) An empirical analysis of the ethical reasoning of tax practitioners. *Journal of Business Ethics* 114(2): 325–339.
- Doyle E, Frecknall-Hughes J and Summers B (2014) Ethics in tax practice: A study of the effect of practitioner firm size. *Journal of Business Ethics* 122(4): 623–641.
- Dubin JA, Graetz MA, Udell MA, et al. (1992) The demand for tax return preparation services. *Review of Economics and Statistics* 74(1): 75–82.
- Duncan W, LaRue DW and Reckers PMJ (1989) An empirical examination of the influence of selected economic and noneconomic variables in decision making by tax professionals. *Advances in Taxation* 2: 91–106.
- Erard B (1990) The impact of tax practitioners on tax compliance: A research summary. Paper presented at the *1990 Internal Revenue Service Research Conference*, Washington, DC, November.
- Erard B (1993) Taxation with representation: An analysis of the role of tax practitioners in tax compliance. *Journal of Public Economics* 52(2): 163–197.
- Fischer CM, Wartick M and Mark MM (1992) Detection probability and taxpayer compliance: A review of the literature. *Journal of Accounting Literature* 11: 1–48.
- Fisher A (1994) Finding the right tax adviser. *Fortune*, 21 March, 159–161.
- Fisher R and Ury W (1981) *Getting to Yes*. Boston, MA: Houghton Mifflin.
- Foreman A (1996) *The Allied Dunbar Tax Handbook 1996–97*. London: Pitman.
- Frecknall-Hughes J and McKerchar M (2013) Historical perspectives on the emergence of the tax profession. *Australian Tax Forum* 28(2): 276–288.
- Frecknall-Hughes J and Moizer P (1999) Taxation and ethics. In: Lamb M and Lymer A (eds) *Interdisciplinary Research in Taxation: Research Approaches and Bibliographic Survey*. London: ICAEW, Centre for Business Performance, pp. 73–84.

- Frey BS (1997) *Not Just for the Money: An Economic Theory of Personal Motivation*. Cheltenham: Edward Elgar.
- Frischmann PJ and Frees EW (1999) Demand for services: Determinants of tax preparation fees. *Journal of the American Taxation Association* 21(Suppl.): 1–23.
- Fuller C (2013) Big four to appear before public accountants committee. *Accountancy Age*, 21 January. Available at: <http://www.accountancyage.com/aa/news/2237667/big-four-to-appear-before-public-accounts-committee> (accessed 18 August 2013).
- Grasmick HG and Green DE (1980) Legal punishment, social disapproval and internationalisation as inhibitors of illegal behavior. *Journal of Criminal Law and Criminology* 71: 323–335.
- Gurley III AL (1996) *Tax avoidance by individuals: Paid-preparer versus self-prepared returns*. PhD Thesis, University of Mississippi, USA.
- Hammer S (1996, January), AICPA statements on responsibilities in tax practice. *The CPA Journal*, 43.
- Hasseldine J and Morris G (2013) Corporate social responsibility and tax avoidance: A comment and reflection. *Accounting Forum* 37(1): 1–14.
- Helleloid RT (1989) Ambiguity and evaluation of client documentation by tax professionals. *Journal of the American Taxation Association* 11(1): 22–36.
- Hemans D (1996) November, Choosing the right tax professional. *Black Enterprise*, 127–129.
- Hite PA and McGill GA (1992) An examination of taxpayer preference for aggressive tax advice. *National Tax Journal* 45(4): 389–401.
- Hite PA and Stock T (1995) The effect of practitioner recommendations on the tax judgments of small business owners and managers. *Law & Policy* 17(1): 161–187.
- Hite PA, Stock T and Cloyd CB (1992) Reasons for preparer usage by small business owners: How compliant are they? *National Public Accountant* 37: 20–26.
- Hite P, Hasseldine J, Al-Khoury A, et al. (2003) Tax practitioners and tax compliance. In: Lymer A and Salter D (eds) *Contemporary Issues in Taxation Research*. Warwick: Ashgate Publishing Limited, pp. 17–43.
- HMRC (2009) *Modernising Powers, Deterrents and Safeguards. Working with Tax Agents: A Consultation Document*. London, UK: HMRC.
- Jackson BR and Milliron VC (1989) Tax preparers: Governments agents or client advocates? *Journal of Accountancy* 167(5): 76–83.
- Johnson LM (1993) An empirical investigation of the effects of advocacy on preparers' evaluations of judicial evidence. *Journal of the American Taxation Association* 15(1): 1–22.
- Kaplan SE, Reckers PMJ, West SG, et al. (1988) An examination of tax reporting recommendations of professional tax preparers. *Journal of Economic Psychology* 9(4): 427–443.
- Kinsey K (1987) Advocacy and perception: The structure of tax practice. Working paper, American Bar Foundation.
- Kirchler E (2007) *The Economic Psychology of Tax Behavior*. Cambridge: Cambridge University Press.
- Kirchler E, Hoelzl E and Wahl I (2008) Enforced versus voluntary tax compliance: The 'slippery slope' framework. *Journal of Economic Psychology* 29(2): 210–225.
- Kirchler E, Muehlbacher S, Kastlunger B, et al. (2010) Why pay taxes: A review on tax compliance decisions. In: Alm J, Martinez-Vasquez J and Torgler B (eds) *Developing Alternative Frameworks for Explaining Tax Compliance*. London: Routledge, pp. 15–32.

- Klepper S and Nagin N (1989a) The role of tax practitioners in tax compliance. *Policy Sciences* 22: 167–192.
- Klepper S and Nagin N (1989b) Tax compliance and the perceptions of the risks of detection and criminal prosecution. *Law & Society Review* 23: 209–240.
- Klepper S, Mazur M and Nagin N (1991) Expert intermediaries and legal compliance: The case of tax preparers. *Journal of Law and Economics* 34(1): 205–229.
- Kogler C, Batrancea L, Nichita A, et al. (2013) Trust and power as determinants of tax compliance: Testing the assumptions of the slippery slope framework in Austria, Hungary, Romania and Russia. *Journal of Economic Psychology* 34(1): 169–180.
- Kressel K and Wall J (2012) Introduction to the special issue on mediator style. *Negotiation and Conflict Management Research* 5(4): 334–339.
- Krouse S and Baker S (2012) Osborne clamps down on tax abuse. *Financial News*. Available at: <http://www.efinancialnews.com/story/2012-03-21/osbourne-clamps-down-on-tax-abuse-in-budget> (accessed 29 December 2012).
- LaRue D and Reckers PMJ (1989) An empirical investigation of the influence of selected factors on professional tax preparers' decision processes. *Advances in Accounting* 7: 37–50.
- Leviner S and Richison K (2011) Tax preparers and the role they play in taxpayer compliance. An empirical investigation with policy implications. Buffalo Legal Studies Research Paper Series, Paper No. 2011-021. Available at: <http://ssrn.com/abstract=1884188> (accessed 10 April 2013).
- Lubbe M and Nienaber G (2012) Do South African small business prefer conservative tax advice to aggressive tax advice? *International Business & Economic Research Journal* 11(6): 697–712.
- Marshall RL, Armstrong RW and Smith M (1998) The ethical environment of tax practitioners: Western Australian evidence. *Journal of Business Ethics* 17(12): 1265–1279.
- Martin D, Herbig P, Howard C, et al. (1999) At the table: Observations on Japanese negotiation style. *American Business Review* 17(1): 65–70.
- McGill GA (1988) *The CPA's role in income tax compliance: An empirical study of variability in recommending aggressive tax positions*. PhD Thesis, Texas Tech University, USA.
- McKerchar M, Bloomquist K and Leviner K (2008) Improving the quality of services offered by tax agents: Can regulation help? *Australian Tax Forum* 23(4): 399–425.
- Milliron VC and Toy DR (1988) Tax compliance: Investigation of key features. *Journal of the American Taxation Association* 9(2): 84–104.
- Muehlbacher S and Kirchler E (2010) Tax compliance by trust and power of authorities. *International Economic Journal* 24(4): 607–610.
- Muehlbacher S, Kirchler E and Schwarzenberger H (2011) Voluntary versus enforced compliance: Empirical evidence for the 'slippery slope' framework. *European Journal of Law and Economics* 32(1): 89–97.
- Newberry KJ, Reckers PMJ and Wyndelts RW (1993) An examination of tax practitioner decisions: The role of preparer sanctions and framing effects associated with client condition. *Journal of Economic Psychology* 14(2): 439–452.
- Niemirowski P and Wearing A (2003) Taxation agents and taxpayer compliance. *Journal of Australian Taxation* 6(2): 166–200.
- OECD (2008) *Study into the Role of Tax Intermediaries*, Fourth OECD Forum on Tax Administration, Cape Town, South Africa.

- OECD (2013) Co-operative compliance: A framework from enhanced relationship to co-operative compliance. Available at: <http://www.oecd.org/ctp/administration/Co-operative-Compliance-Preliminary.pdf> (accessed 8 October 2013).
- Oxford English Dictionary (1993) *Compact Edition*. Oxford: BCA by arrangement with Oxford University Press.
- Pei BKW, Reckers PMJ and Wyndelts RW (1992) Tax professionals belief revision: The effects of information presentation sequence, client preference and domain experience. *Decision Sciences* 23(1): 175–199.
- Pruitt DG (1971) Indirect communication and the search for agreement in negotiation. *Journal of Applied Social Psychology* 1: 205–238.
- Reckers PMJ, Sanders DL and Wyndelts RW (1991) An empirical investigation of factors affecting tax practitioner compliance. *Journal of the American Taxation Association* 13(2): 30–46.
- Reinganum JF and Wilde LL (1988) Tax practitioners and tax compliance. *Social Science Working Paper No. 666*, California Institute of Technology, Pasadena.
- Reinganum JF and Wilde LL (1990) Equilibrium enforcement and compliance in the presence of tax practitioners. *Social Science Working Paper No. 744*, California Institute of Technology, Pasadena.
- Roark S (1986) *An examination of risk attitudes in legal tax research*. PhD Thesis, Arizona State University, USA.
- Roth JA, Scholtz JT and Witte AD (1989) *Taxpayer Compliance: An Agenda for Research*, Vol. 1. Philadelphia, PA: University of Pennsylvania Press.
- Sakurai Y and Braithwaite V (2003) Taxpayers' perceptions of practitioners: Finding one who is effective and does the right thing? *Journal of Business Ethics* 46(4): 375–387.
- Sawyers RB (1990) *The impact of uncertainty and ambiguity on income tax decision making*. PhD Thesis, Arizona State University, USA.
- Schisler DL (1994) An experimental examination of factors affecting tax preparers' aggressiveness – A prospect theory approach. *Journal of the American Taxation Association* 16(2): 124–142.
- Schmidt D (2001) The prospects of taxpayer agreement with aggressive tax advice. *Journal of Economic Psychology* 22(2): 157–172.
- Scotchmer S (1989) The effect of tax advisors on tax compliance. In: Roth JA and Scholtz JT (eds) *Taxpayer Compliance: Social Science Perspectives*, Vol. 2. Philadelphia, PA: University of Pennsylvania Press, pp. 182–199.
- Scotchmer S and Slemrod J (1989) Randomness in tax enforcement. *Journal of Public Economics* 38(1): 17–32.
- Seldon A (ed) (1979) *Tax Avoidance: The Economic, Legal and Moral Inter-Relationships Between Avoidance and Evasion*. London: Institute of Economic Affairs.
- Shafer WE and Simmons RS (2008) Social responsibility, Macchiavellianism and tax avoidance. A study of Hong Kong tax professionals. *Accounting Auditing & Accountability Journal* 21(5): 695–720.
- Sikka P (2010) Smoke and mirrors: Corporate social responsibility and tax avoidance. *Accounting Forum* 34(3–4): 153–168.
- Slemrod J (1989) Complexity, compliance costs and tax evasion. In: Roth JA and Scholtz JT (eds) *Taxpayer Compliance: Social Science Perspectives*, Vol. 2. Philadelphia, PA: University of Pennsylvania Press, pp. 156–181.



- Smith KW and Kinsey KA (1987) Understanding taxpayer behavior: A conceptual framework with implications for research. *Law & Society Review* 12(4): 640–663.
- Spilker BC, Worsham RG and Prawitt DF (1999) Tax professionals' interpretations of ambiguity in compliance and planning decision contexts. *Journal of the American Taxation Association* 21(2): 75–89.
- Stainer A, Stainer L and Segal A (1997) The ethics of tax planning. *Business Ethics: A European Review* 6(4): 213–219.
- Stephenson T (2006) The gap between what taxpayers want and what tax professionals think they want: A reexamination of client expectations and tax professional aggressiveness. *University of Kentucky Doctoral Dissertations*. Paper 278. Available at: [http://uknowledge.uky.edu/grad-school\\_diss/278](http://uknowledge.uky.edu/grad-school_diss/278) (accessed 3 April 2013).
- Strauss A (1978) *Negotiations*. San Francisco: Jossey-Bass.
- Swingen JA, Greene PM and Long SB (1991) *Taxpayer compliance burdens: An examination of factors affecting tax return preparation fees*. Paper presented at the Annual Law and Society Association Meetings, Amsterdam, The Netherlands, June.
- Tan LM (1999) Taxpayers' preference for type of advice from tax practitioner: A preliminary examination. *Journal of Economic Psychology* 20(4): 431–447.
- Thuronyi V and Vanistendael F (1996) Regulation of tax professionals. In: Thuronyi V (ed) *Tax Law Design and Drafting*. Washington, DC: International Monetary Fund, pp. 135–163.
- Tittle CR (1980) *Sanctions and Social Deviance: The Question of Deterrence*. New York, NY: Praeger.
- Tomasic R and Pentony B (1991) Taxation law compliance and the role of professional tax advisers. *Australian & New Zealand Journal of Criminology*, 24: 241–257.
- Torgler B (2007) *Tax Compliance and Tax Morale: A Theoretical and Empirical Analysis*. Cheltenham: Edward Elgar Publishing.
- US Internal Revenue Service (1988) Tables 20 and 21, selected statistical series. *Statistics of Income Bulletin*, Winter 1987–1988.
- Wahl I, Kastlunger B and Kirchler E (2010) Trust in authorities and power to enforce tax compliance: An empirical analysis of the 'slippery slope framework'. *Law & Policy* 32(4): 383–406.
- Wall JA Jr (1985) *Negotiation Theory and Practice*. Glenville, IL: Scott Lovesman.
- Weigel R, Hessing DJ and Elffers H (1987) Tax evasion research: A critical appraisal and theoretical model. *Journal of Economic Psychology* 8(2): 215–235.
- Westat, Inc (1987) *A Survey of Tax Practitioners*. Prepared for the Internal Revenue Service, USA.
- White M (1990) Why are taxes so complex and who benefits? *Tax Notes* 16: 341–354.
- Wilson R (2009) An examination of corporate tax shelter participants. *Accounting Review* 84(3): 969–999.
- Wyman P (1997) Upholding the law. *Tax Journal* 10: 3–4.
- Yankelovich, Skelly and White, Inc (1984) *Survey of Taxpayer Attitudes: Final Report*. Washington, DC: Internal Revenue Service.
- Yetmar SA and Eastman KK (2000) Tax practitioners' ethical sensitivity: A model and empirical examination. *Journal of Business Ethics* 26(4): 271–288.
- Young HP (1991) Negotiation analysis. In: Young H (ed) *Negotiation Analysis*. Ann Arbor, MI: University of Michigan Press, pp. 1–24.

**Cases cited**

*Ayrshire Pullman Motor Services and Ritchie v. CIR* [1929] (14 TC 574).

*Gregory v. Helvering, Commissioner of Internal Revenue, US Supreme Court* [1935] (94-TNT-241-61).

*IRC v. Duke of Westminster* [1936] AC 1.

*Ramsay (W.T.) Ltd v. CIR* [1982] AC 300.

*Re Weston's Settlements* [1969] 1 Ch 223.